

FREMA

MODEL SR-30 SLAB ROLLER
OWNER'S MANUAL



The SR-30 SLAB ROLLER ships complete in 4 cartons.
 Carton 4-1: Table frame 4-2: Slab rolling unit and leveling handle
 4-3: Tabletop & canvas 4-4: Wagon Wheel & Crank Handles.

Assembly

Open carton 4-1. Inside are 4 legs, 2 side rails with latches, 2 end rails, 2 slab roller mounting brackets and a hardware package. Assemble the 4 legs to the side and end rails using M10 X 20 cap screws and M10 hex nuts. Start by attaching legs to side and end rails, upside down, with a single bolt tightened by hand. Once assembled, stand upright and insert remaining bolts, tightening each by hand. Finally, tighten all bolts with two 11/16" wrenches.

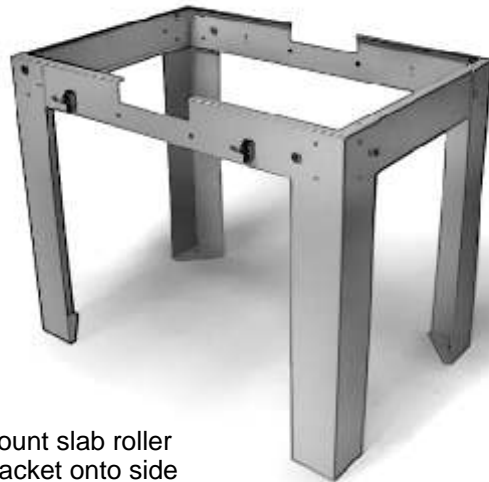
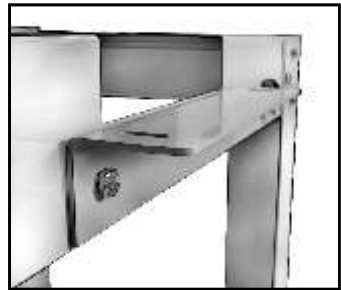
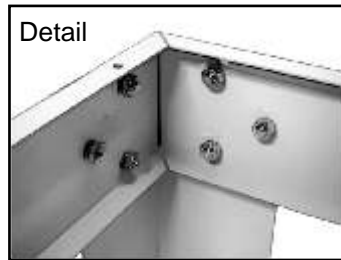

Mount slab roller bracket onto side rails as shown with M10 X 20 cap screws, lock washers and M10 wing nuts.

Open carton 4-2. Remove slab roller unit and position on frame mounting brackets. Secure using M6 X 20 socket cap screws, washers, lock washers and M6 wing nuts.

Slab roller bolted to table frame.

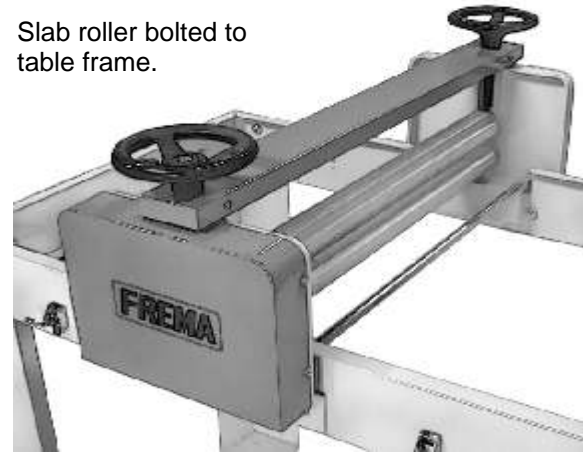

Screw handles onto the 2 slab roller leveling wheels.



Open carton 4-3. Remove table top halves. Fasten the clasp brackets to the underside of the tops with M5 X 30 flat head socket cap screws and wing nuts as illustrated. Position table tops on either side of the roller and secure to the frame with the 4 clamps.



Underside



Top



Open carton 4-4. Select the crank or wagon wheel handle, loosen the set screw, and slide the handle onto the shaft so that handle notch engages with the shaft pin. Tighten the set screw.

Operation:

Raise the upper roller with either leveling handle. Lay canvas on one side of the table. Place wire-sliced clay onto the canvas so that the slices overlap one another. Arrange them perpendicular to the rollers and tapered a little nearest the rollers to facilitate feed. Cover with canvas and feed the "sandwich" up to the rollers. Set the desired thickness with a leveling handle and begin feeding the clay into the rollers, turning the crank or wagon wheel at the same time. If the emergent slab is too small or has holes, simply reverse, add clay where required and run it through again.



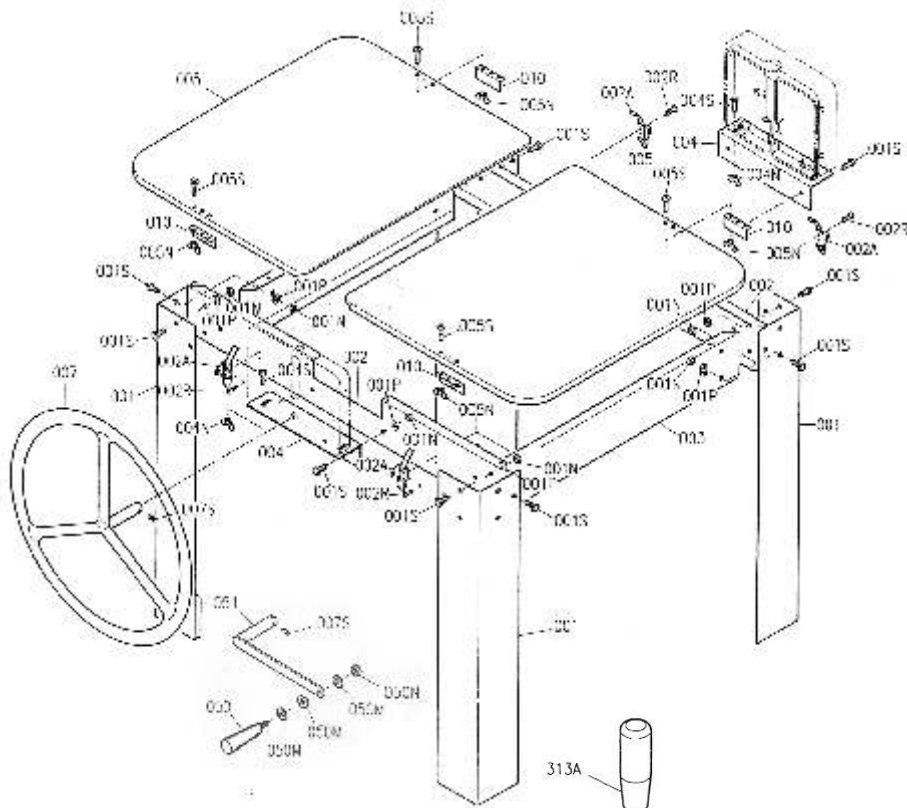

FRAME ASSEMBLY & TABLE TOP

- 001 Table Leg
- 001N Hex Nut
- 001P Lock Washer
- 001S Hex Head Screw
- 002 Side Rail
- 002A Latch
- 002R Rivet
- 003 End Rail
- 004 Mounting Bracket
- 004N Wing Nut
- 004S Hex Head Screw
- 005 Table Top
- 005N Wing Nut
- 005S Flat Head Screw
- 007 Wagon Wheel Handle
- 007S Socket Head Set Screw
- 010 Clasp Bracket
- 050 Grasp Handle
- 050M Nylon Washer
- 050N Hex Nut
- 051 Crank Handle

SLAB ROLLER

- 006 Gear Guard
- 006S Round Head Screw
- 006W Washer
- 007P Pin
- 011 Indication Label
- 013 Bushing
- 014 Adjusting Screw
- 015 Spacer Bar
- 015P Lock Washer
- 015S Hex Head Screw
- 016 Riser Block
- 018D Hex Head Bolt
- 018N Hex Nut

- 018U Hex Head Bolt
- 018W Washer
- W019 Spacer
- 019N Hex Nut
- 019S Round Head Screw
- 019W Washer
- 024A Gear End Housing
- 024B Crank End Housing
- 026 Spacer Strap
- 030D Bottom Roller
- 030P Pin
- 030S Hex Head Screw
- 030W Washer
- 030U Top Roller
- 038 Nylon Washer
- 039 Nylon Washer

- 060 Drive/Driven Gear (same)
- 061 Small Idler Gear
- 062 Large Idler Gear
- 064 Thickness Pointer
- 067 Spacer Strap
- 112 Chain Cover
- 113 Gear Cover
- 113S Round Head Screw
- 210 Sprocket Gear
- 210S Socket Head Set Screw
- 211 Chain
- 313 Handwheel
- 313A Handle
- 313N Hex Nut
- 313S Socket Head Set Screw

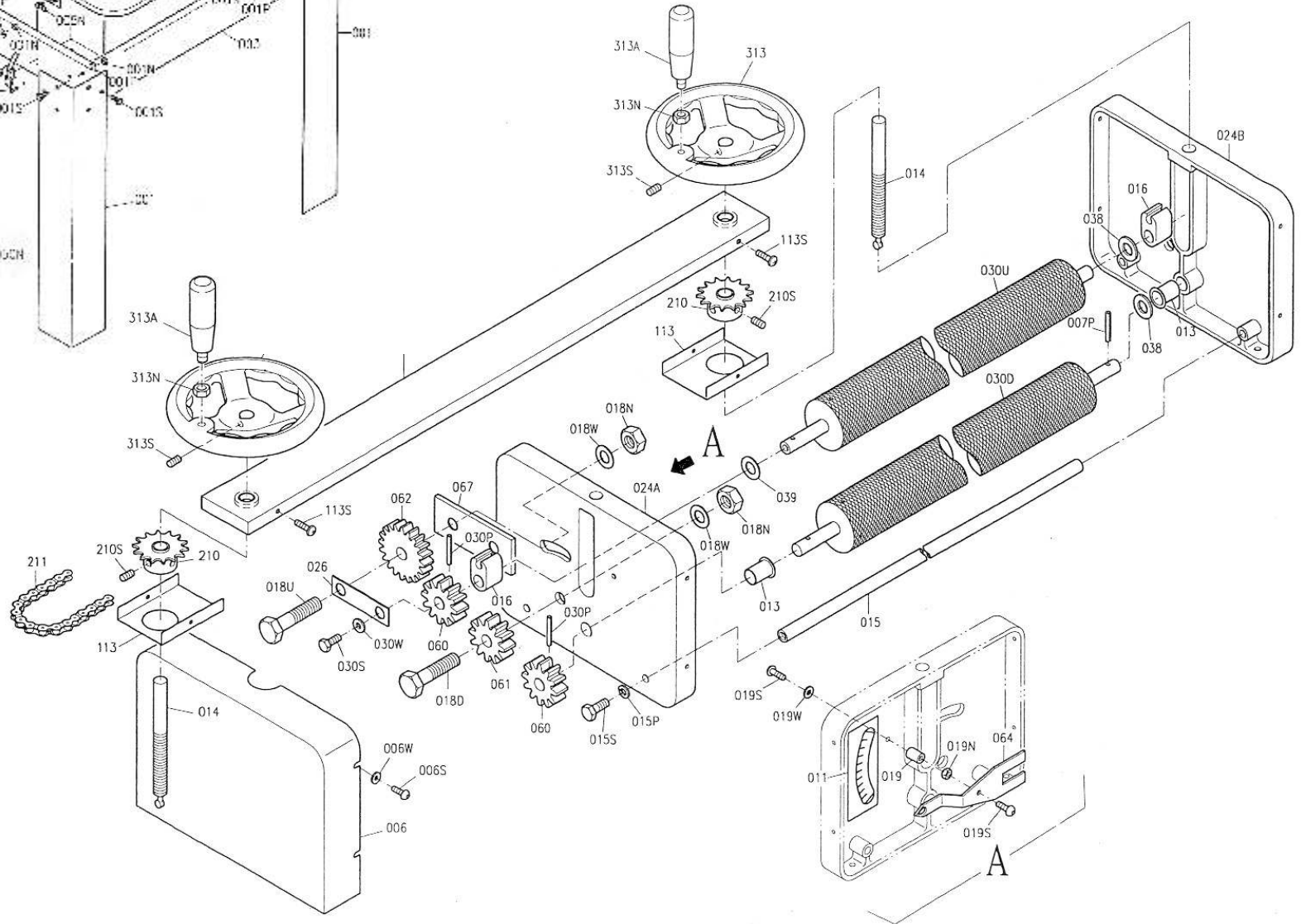

HARDWARE PACKAGE



28 each, M10X20 cap screw, hex nut and lock washer. To fasten side rails, end rails and legs together and to fasten roller unit mounting brackets to side rails.



4 each, M6X20 cap screw, wing nut, washer and lock washer. To fasten rolling unit to the mounting bracket.



12 each, M5X30 cap screw, wing nut, and lock washer. To fasten clasp brackets to table top.

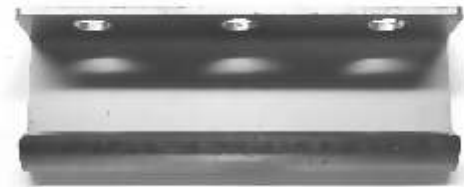

4 only clasp brackets - for mounting to underside of table top sections.



1 each, M3, M4 & M5 short arm hex keys for tightening screw-nut-washer combinations



3 only M5X25 spare spring pins



4 only 1/4" X 3/4" wood screws for securing table top to side and end rails once roller unit has been removed to create a work table.

Maintenance

For optimum long term performance, gears and other moving contact points require periodic greasing. Gears can be accessed by removing the gear guard 006 by loosening screws 006S. Apply to all gears. Also, apply grease to the area where adjusting screw 014 and riser block 016 engage.



FREMA
MODEL SR-30 SLAB ROLLER



THE POTTERY SUPPLY HOUSE
LIMITED

1120 Speers Road, Oakville, ON, Canada L6L 2X4 Tel: 800-465-8544
mail@pshcanada.com mail@euclids.com pshcanada.com euclids.com